

technical reprint

R/P087



photomultipliers; their importance in ATP work

photomultipliers; their importance in ATP work

R J Ellis and A G Wright, Electron Tubes Limited, Bury Street, Ruislip, Middlesex HA4 7TA

technical reprint RP/087

introduction

Bioluminescence processes used in the detection and measurement of ATP are generally characterised by weak or short-lived emission of light in the wavelength range 400 to 600 nm. Most commercial luminometers available for this application are fitted with photomultiplier tubes, operating in the photon counting mode (1).

We explain why the photomultiplier remains the first choice detector for bioluminescence and chemiluminescence applications and recommend how it should be operated to obtain the best results. These recommendations are intended as a guide for luminometer designers and for those who are involved in the selection and operation of luminometer systems.

1 the photomultiplier

The photomultiplier combines a large area photo-sensitive surface, to convert photons into photo-electrons, with an electron multiplier that operates as a very low noise, high gain, and wideband amplifier. It provides an output charge that is proportional to input light intensity and which is easily measured or processed by readily available electronic circuits.

2 choice of photocathode

Referring to figure 1, we note that the spectral response of the Sb-K-Cs bialkali photocathode is well matched to the spectral emission of aequorin. The Na-Sb-K-Cs(S20) trialkali might appear the best choice for firefly luciferase, however, photomultipliers with this photocathode are typically 2 to 3 times more expensive than the bialkali types and their higher dark emission will reduce overall sensitivity and dynamic range. In practice a photomultiplier with an Sb-K-Cs or Rb-Cs bialkali photocathode is invariably the better choice.

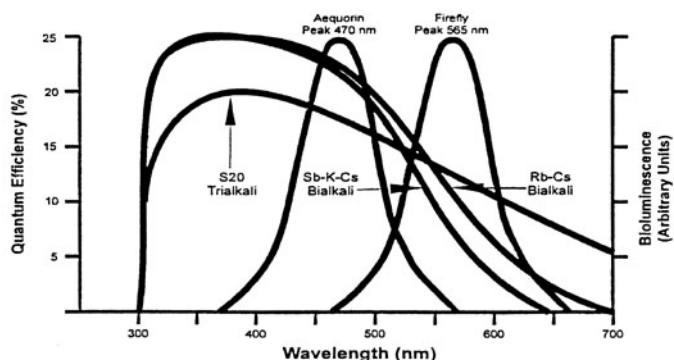

figure 1 emission spectra of two of the more widely used bioluminescent materials compared with typical spectral response characteristics of three widely used photocathode types. The emission spectra are not normalised.

3 light collection

By way of illustration, figure 2 shows a simple arrangement in which a point light source is at a distance equal to the active diameter of the photocathode. Based on straightforward solid angle considerations, only 5% of the emitted light reaches the photomultiplier. For very weak light sources this will need to be improved, for example by use of reflective surfaces or a light guide, to ensure adequate detection efficiency and signal to noise ratio.

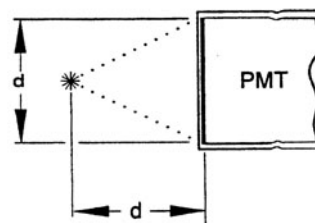

figure 2 light collection from a point source

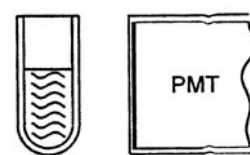

figure 3 light collection from a cuvette

Figure 3 shows a schematic of a cuvette containing light emitting material. The volume of light emitting material, the height and diameter of the liquid column and the position of the liquid column with respect to the photocathode should all be controlled to ensure repeatability from measurement to measurement. It should also be appreciated that light emission from a liquid column of this form tends to be concentrated at the hemispherical base and at the meniscus(2).

The size and shape of the light source will influence the choice of photomultiplier tube – side window or end window – and size of the photocathode. It can be seen that a larger photocathode may be advantageous in some applications.

4 detection efficiency

Each photon incident on the photomultiplier window has a wavelength dependent probability of releasing a photoelectron. This probability is known as the quantum efficiency (QE) and is normally expressed as a percentage. The specified QE includes optical transmission and reflection losses associated with the photomultiplier window.

Not all photoelectrons released from the photocathode reach the first dynode and result in an output pulse from the photomultiplier. First dynode collection efficiency (f) is a function of the structure and operating conditions of the photomultiplier and typically varies from 70% for side window tubes to 90 – 95% for some end window types.

Detection efficiency is the product of QE and f . In the case of a 565 nm point source, positioned as shown in figure 2, and end window Sb-K-Cs alkali photocathode photomultiplier would detect less than 10% of incident light, hence less than 0.5% of emitted light.

5 the multiplication process

Photoelectrons emitted from the photocathode are accelerated and focused onto the first dynode of an electron multiplier. On impact, each photoelectron liberates a number of secondary electrons that are, in turn, accelerated and focused onto the next dynode. The process is repeated at each subsequent dynode and the secondary electrons from the last dynode are collected at the anode.

The ratio of secondary to primary electrons at each dynode, and hence the gain at each stage, depends on the energy of the incident primaries and is a function of the interdynode potential. The use of a variable high voltage power supply, in conjunction with a voltage divider network to provide interelectrode potentials, enables the gain of the electron multiplier to be varied over a wide dynamic range.

6 photomultiplier output pulse

Figure 4 shows a typical output pulse from a photomultiplier operating at 10^7 gain, resulting from a single detected photon.

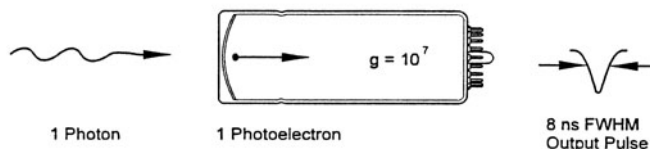

figure 4 typical photomultiplier output pulse from a single detected photon.

The output pulse is delayed and spread in time as a result of the range of initial velocities and path lengths of electrons travelling through the dynode structure. In this example the average charge in the output pulse, given by the product of the electronic charge ($e = 1.6 \times 10^{-19}$ C) and the gain (10^7), is 1.6 pC. The average pulse height will be about 200 μ A or 10 mV across a 50 Ω load.

7 photon counting

To count these pulses, and to discriminate against smaller output pulses originating from intermediate dynodes or from external electrical interference, we need an amplifier/discriminator.

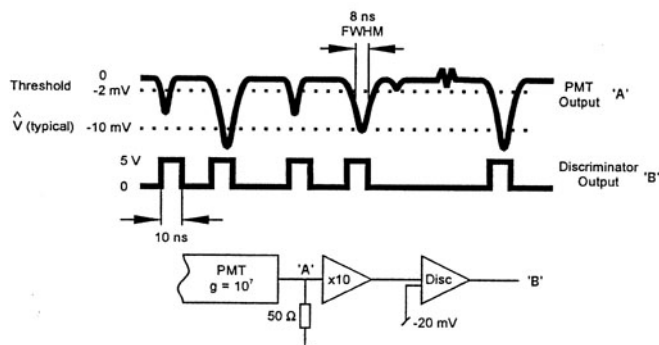

figure 5 general form of input and output pulses from a TTL output discriminator.

In the example shown in figure 5, the discriminator threshold is set to -20 mV giving a sensitivity of -2 mV at the anode. Note the one 'small' pulse and the electrical interference which fall below this threshold and are ignored.

8 plateau characteristic

To ensure that the photomultiplier tube is operated at the optimum gain for photon counting, the appropriate high voltage should be established by reference to a plateau characteristic, as shown in figure 6:

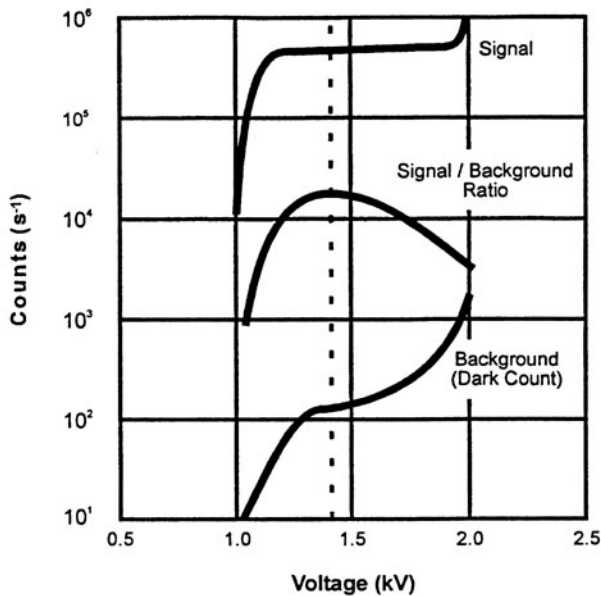

figure 6 plateau characteristic.

In **figure 6** the signal characteristic shows the relationship of output counts against applied photomultiplier voltage, for a fixed light input and a fixed discriminator threshold. The knee of the characteristic indicates the voltage at which the majority of photomultiplier pulses resulting from single detected photons exceeds the discriminator threshold. When operating on the plateau it can be seen that output counts are largely independent of small changes in high voltage, photomultiplier gain and threshold setting. Small pulses arising from electrons emitted from intermediate dynodes fall below the discriminator threshold and are ignored.

A similar plot of background or dark counts, with light excluded from the photomultiplier, generally shows a less pronounced plateau with higher slope.

The preferred choice of operating voltage is somewhat dependent on application but is normally towards the lower voltage end of the plateau, where the signal to background ratio is optimised. Operating in this region also minimises the incidence of time correlated afterpulses which could adversely affect counting statistics and timing.

In a well-designed photon counting system the counting efficiency, defined as the ratio of measured counts to incident photon flux, can be assumed to be equal to the detection efficiency.

Counting efficiency will vary from tube to tube of a particular photomultiplier tube type, due to variations in quantum efficiency. Users are strongly recommended not to try to calibrate or normalise outputs from photon counting systems by adjusting photomultiplier tube operating voltages. An optical filter or aperture at the input is preferred, however,

care should be taken to ensure that an aperture does not make the system over-sensitive to variations in the size or position of the light source.

9 signal to noise

The photoelectric effect is a quantum mechanical process subject to fluctuations described by Poisson statistics.

A steady light source generating M photoelectrons per second for a period of T seconds, will produce an average of MT photoelectrons, with a standard deviation of $(MT)^{1/2}$. Hence, signal-to-noise ratio is given by:

$$MT/(MT)^{1/2} = (MT)^{1/2}$$

table 1 photocathode noise and signal-to-noise ratio

signal counts MT	noise counts $(MT)^{1/2}$	Noise, % of signal	SNR, $(MT)^{1/2}$
10	3.2	32	3.2
100	10	10	10
10,000	100	1	100
1,000,000	1,000	0.1	1,000

From **table 1** it can be seen that MT should be maximised to obtain best signal-to-noise ratio. Increasing measurement time, T , may not be appropriate particularly where the light being measured is itself a function of time. Count rate, M , should be as high as possible, consistent with the maximum count rate capability of the amplifier/discriminator and associated electronics.

The noise figure is a measure of the statistical significance of the signal. It should not be confused with the background, also referred to as dark count or dark current, which is the unwanted source of signal.

10 background

Background is the signal produced by the photomultiplier when there is no light incident on the photocathode. It comprises a temperature related component, principally thermionic electrons emitted from the photocathode, together with temperature independent contributions from afterpulses, natural radioactivity and cosmic radiation.

For an Sb-K-Cs bialkali photocathode the background is largely independent of temperature below about 25 °C but increases by a factor of 2 for every 5 °C above this temperature. For applications involving bioluminescent materials maintained at

37 °C it might be advantageous to introduce a thermal barrier or to cool the photomultiplier tube.

11 dynamic range – photon counting

Over its useful operating range, the photomultiplier will produce an output count rate which is proportional to incident light power.

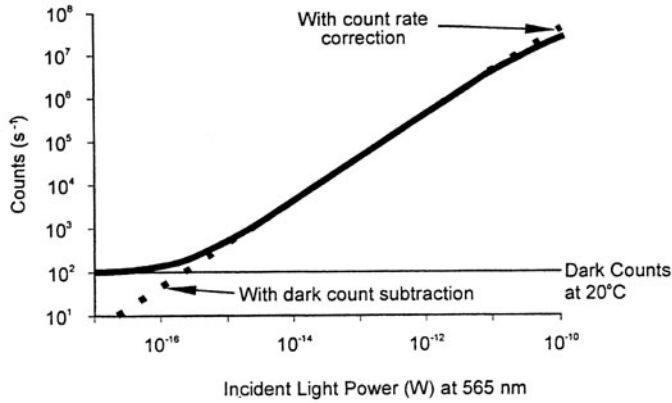

figure 7 typical dynamic range in photon counting mode.

With reference to **figure 7**, consider an Sb-K-Cs bialkali photocathode photomultiplier tube with 10% QE at 565 nm and a first dynode collection efficiency of 90%. The energy of a 565 nm photon is 3.52×10^{-19} J from which the responsivity of photon counting system to bioluminescence from firefly luciferase can be calculated as typically $250,000 \text{ s}^{-1}$ per pW of light incident on the photocathode.

At low count rates the effect of background or dark counts becomes significant. As already seen, some improvement may be obtained by cooling, or at least by preventing the tube from being heated. Dark count subtraction can be used down to the point at which signal becomes less than about 1/10 of background. Beyond this the statistical uncertainty associated with the subtraction process becomes excessive.

At high count rates the dynamic range is limited by the ability of the discriminator to resolve adjacent pulses. Essentially it will ignore pulses that arrive when it is already busy with a previous pulse. This busy period is referred to as 'dead time'. For an ideal, non-paralisable discriminator, the deviation from count rate linearity due to pulse pile-up will be of the form:

$$N = n/(1 - nT)$$

where N is the true count rate, n is the measured count rate and T is the dead time.

In practice, this expression can be used reliably for $nT \ll 0.5$. The correction may become unpredictable for count rates outside this range, and will depend

on the recovery performance of the particular discriminator.

By use of dark count subtraction and dead time correction a dynamic range of more than six orders of magnitude is readily achieved.

12 dynamic range – current mode

Where the pulse rate is too high to resolve and count as individual pulses, the mean current from the photomultiplier anode should be taken as a measure of the light intensity. This is the analogue or current mode.

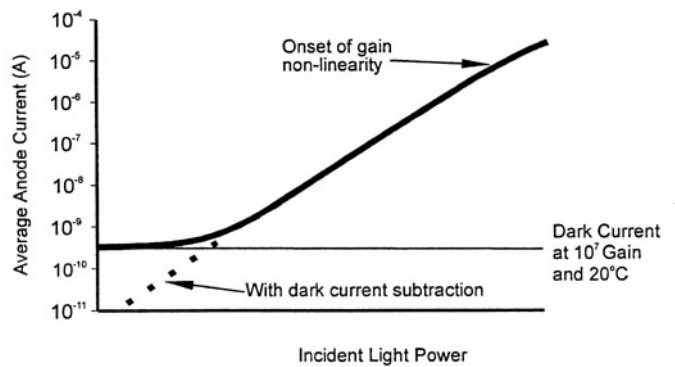

figure 8 typical dynamic range in analogue or current mode

Over its useful operating range, and at a fixed voltage, the photomultiplier will produce an output current that is proportional to incident light power. Output current, I_a , is given by:

$$I_a = NeG$$

Where N is the rate of emission of photoelectrons from the photocathode, e is the electronic charge (1.6×10^{-19} C) and G is the gain of the photomultiplier.

Detectivity at the low current end of the dynamic range is determined by dark current that will also include a leakage component. As with photon counting, dynamic range can be extended by cooling or by dark current subtraction.

The high anode current limitation to dynamic range is due to the onset of non-linearity resulting from a combination of tube and voltage divider effects.

For a typical Sb-K-Cs bialkali tube, operated at a fixed high voltage the dynamic range might extend over six orders of magnitude, with anode currents ranging from 0.1 nA to 100 μ A. However, the gain of the tube can readily be varied over typically four to five decades by changing the high voltage, making it suitable for measuring a very much greater range of input light levels.

13 discussion

photon counting or current mode?

Photon counting is the preferred operating mode (3), (4). It offers better signal-to-noise ratio, related only to the counting statistics of the photocathode, and not to the combined effects of photocathode and multiplier noise. Background is lower, since it excludes contributions from electrical leakage and from emissions from dynodes, and is less affected by external interference - hence detectivity is superior. It is less sensitive to changes in photomultiplier gain, high voltage or temperature.

Current mode operation is appropriate for applications involving high light levels, beyond the count rate capability of a photon counting system, where it is not convenient to use an optical filter or aperture. By varying the high voltage to control photomultiplier gain, a dynamic range of 10 orders of magnitude can be achieved.

photomultiplier or silicon detector?

Photomultipliers have spectral response characteristics that are largely determined by the work function of the photocathode material and by optical absorption in the window. Peak response is typically 350 nm to 450 nm.

By contrast, silicon photodiodes and avalanche photodiodes have spectral response characteristics that are a function of the depletion depth and the optical absorption coefficient of the silicon. Peak response is around 850 to 1000 nm. Their major strength is undoubtedly high quantum efficiency, typically 80%, in the green and red regions of the spectrum. They are physically small, rugged and largely insensitive to external electric or magnetic fields.

Silicon PIN diodes have no internal gain mechanism and response is limited to typically 0.65 A/W at peak wavelength of 850 nm and around 0.35 Q/W at 565 nm. Nevertheless, these devices are low cost and easy to use. They find applications in instruments where incident light levels are relatively high, say, $>10^5$ photons s^{-1} .

Large area avalanche photodiodes (APDs), up to 20 mm diameter, are available with gain capability of up to 10^3 . Although this gain is noisy compared with a photomultiplier, it does extend their use to lower light levels than can be achieved with PIN diodes.

Certain types of APDs have single photon counting

capability, but availability is currently restricted to small area devices of less than 0.5 mm diameter. With reference to figures 2 and 3, it can be seen that this is likely to impose severe limitations on light collection, and hence on system detectivity by more than offsetting the benefit of higher QE.

Photon counting APDs are characterised by a steep gain-voltage relationship, which is strongly dependent on temperature, and a dark count rate that typically doubles for every 10 °C rise. The consequent need for additional hardware to maintain these devices at a closely controlled, sufficiently low temperature, typically -20 °C to -40 °C, to reduce dark counts to an acceptable level, effectively compromises the potential advantages of small physical size, low weight and low power consumption.

A typical photon counting APD module, with low voltage input and TTL output and with integral bias voltage supply and thermoelectric cooler, might consume 5 W. By comparison, a photomultiplier based module, also with low voltage input and TTL output, could be of similar overall dimensions and weight but would consume less than 200 mW, making it much more attractive for battery-driven instrument applications.

The count rate capability of photon counting APDs is limited by the recovery time constant associated with the device capacitance. Even with active quenching, by which the APD capacitance is rapidly recharged after each signal pulse, count rates are currently limited to around $2 \times 10^6 s^{-1}$.

Choice of device is ultimately determined by the applications and operating conditions. Photon counting APDs are well suited to some fibre optic communication applications and may offer the only solution for measurement of longer wavelengths beyond the spectral response range of photomultipliers. They are currently unlikely to offer a serious challenge to photomultiplier tubes for use in luminometers for the measurement of ATP.

There are many technical publications comparing the performance of PIN photodiodes, APDs and photomultipliers, however, the technical note from Advanced Photonics (5) is recommended as a useful starting point.

references

- [1] Stanley P E. A Survey of more than 90 Commercially Available Luminometers and Imaging Devices for Light-light Measurement of Chemiluminescence and Bioluminescence. Part 1. J Biolumin Chemilumin. 1992;7:77-108.

- [2] Malcolm P J, Stanley P E. systematically Understanding the Liquid Scintillation Counting Process: A Stochastic Computer Model. In: Liquid Scintillation Counting. Crook M A, Johnson P, Editors. London, Heyden, 1977;4:15-43.
- [3] Oliver C J. A Comparison of Current Measurement with Photon Counting in the use of Photomultiplier Tubes. Reprint R/P 066
- [4] Wright A G. Theoretical and Practical Considerations in the use of Photomultipliers for Low Light Level Measurements. Reprint R/P 083
- [5] Noise Characteristics of Advanced Photonics Avalanche Photodiodes. Advanced Photonics Inc., Application Note. December 1991.

Reprinted from: International Symposium on Industrial Applications for Bioluminescence in Microbiology, ATP96, 25-26 June 1996, Heathrow, UK

**talk to us about your
application or choose a product
from our literature:**

**photomultipliers, voltage dividers,
signal processing modules, housings
and power supplies**



ET Enterprises Limited
45 Riverside Way
Uxbridge UB8 2YF
United Kingdom
tel: +44 (0) 1895 200880
fax: +44 (0) 1895 270873
e-mail: sales@et-enterprises.com
web site: www.et-enterprises.com

ADIT Electron Tubes
300 Crane Street
Sweetwater TX 79556 USA
tel: (325) 235 1418
toll free: (800) 521 8382
fax: (325) 235 2872
e-mail: sales@electrontubes.com
web site: www.electrontubes.com

choose accessories for this pmt on our website

an ISO 9001 registered company

The company reserves the right to modify these designs and specifications without notice. Developmental devices are intended for evaluation and no obligation is assumed for future manufacture. While every effort is made to ensure accuracy of published information the company cannot be held responsible for errors or consequences arising therefrom.

ET Enterprises 
electron tubes

© ET Enterprises Ltd, 2011
DS_ R/P087 Issue 3 (18/01/11)