

technical reprint

R/P081



the determination of photomultiplier temperature coefficients for gain and spectral sensitivity using the photon counting technique

the determination of photomultiplier temperature coefficients for gain and spectral sensitivity using the photon counting technique

A S Singh and A G Wright,
ET Enterprises Limited, Riverside Way,
Uxbridge, UB8 2YF, United Kingdom

technical reprint R/P081

abstract

The output signal of a photomultiplier is sensitive to changes in temperature. Two coefficients are required to specify this dependence: the multiplier gain coefficient α_m and the spectral sensitivity coefficient $\alpha(\lambda)$. α_m and $\alpha(\lambda)$ can be separated by using the photon counting technique. Results, considered to be superior to those previously reported, are presented for a range of photomultiplier types.

introduction

The long term stability of any detector incorporating a photomultiplier is conditional upon the temperature dependence of the photomultiplier response, which itself has two components. The temperature dependence of the photocathode sensitivity and of the multiplier gain need to be separately specified by two independent coefficients. In certain applications it is acceptable to utilize a combined coefficient, which will be referred to as the photomultiplier coefficient. Semi-transparent photocathodes become highly resistive at low temperature¹. At sufficiently high light levels the photocurrent can distort the equipotential of the cathode and thereby suppress photoelectron collection at the first dynode. This was nicely demonstrated¹ in tubes fabricated with a conducting underlayer to the photocathode. Compared with a conventional photocathode these special tubes exhibited a higher response at low temperature. It is clear that to quantify the temperature dependence of a photomultiplier requires a coefficient α_m to account for the multiplier temperature sensitivity and a complex coefficient for the photocathode $\alpha(I_k, \lambda)$ where I_k and λ refer to the cathode current level and the wavelength of the light, respectively. At low and moderate light levels $\alpha(I_k, \lambda) \rightarrow \alpha(\lambda)$ which is the coefficient actually measured in this work. The method adopted is based on the photon counting technique. Under single photon conditions the variation in the count rate is used to deduce $\alpha(\lambda)$ while the shift in the peak of the single electron response relates to α_m . In this way the two coefficients are simultaneously, yet independently, measured.

The literature^{2,3,8} describes mainly the measurement of the photomultiplier temperature coefficient, although authors such as Murray and Manning¹ and Kinard⁴ for example, have attempted to quantify these components separately. In the first instance¹ the photomultiplier was also operated as a diode to provide the photocathode sensitivity coefficient. In principle it is possible to deduce the multiplier coefficient, but in practice this is unreliable, as these authors admit, because the coefficients are small and not easily measured anyway. Kinard⁴ adopted the doubtful procedure of attempting to cool the dynodes alone.

apparatus and method

The apparatus, shown in **figure 1**, consisted of a monochromator (Hilger and Watts Type D292), with a wavelength selection over the range 200 - 1000 nm.

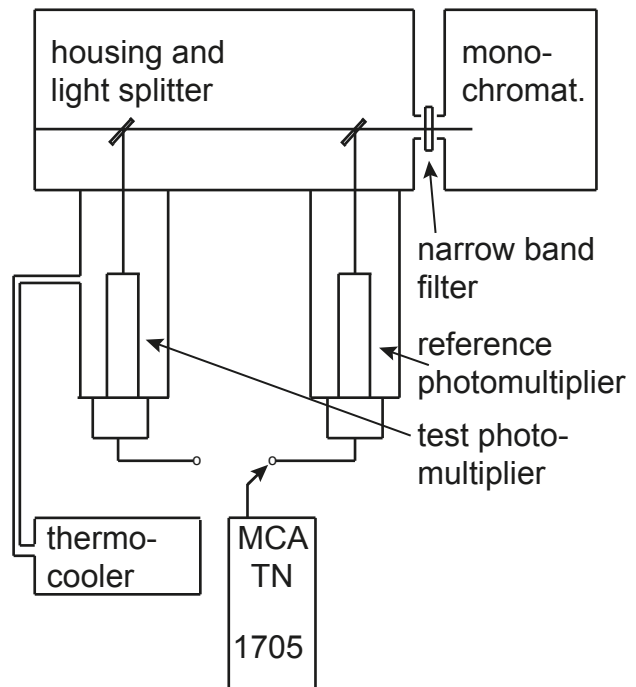

figure 1 schematic layout of the apparatus used to measure temperature coefficients.

Fine wavelength tuning and harmonic elimination was accomplished with narrow band dielectric filters, Balzers B40 15 nm bandwidth, located at the output from the monochromator. Two clear glass slides acted as beam splitters directing approximately equal, very low intensity, light beams to the two photomultipliers. The orientation of the glass slides was adjusted to image the monochromator slit on to the centre of each photocathode. This was accomplished by temporarily substituting the clear plates with mirrors of the same dimensions.

Two photomultiplier housings were rigidly bolted to the main housing. The variable temperature housing, PFR Type TE104 was used in tandem with a thermocirculator. The liquid from the thermocirculator could be varied in temperature from $-2\text{ }^{\circ}\text{C}$ to $+40\text{ }^{\circ}\text{C}$ and served as the heat exchange medium for the thermoelectric cooler. In this manner an overall range from $-20\text{ }^{\circ}\text{C}$ to $+40\text{ }^{\circ}\text{C}$, was attained. The temperature was recorded using the thermocouples attached to the edge of each photocathode window. By using a dummy photomultiplier containing a thermocouple, it was found that the time for the dynodes to reach equilibrium was of the order of half an hour, subsequent to changing the operating temperature; in the experimental work, an hour was allowed to elapse. The photomultipliers were operated from independent positive high voltage supplies; the choice of positive polarity was deliberate because best stability with photomultipliers is always obtained with the earthed cathode configuration. The output pulse height distributions from the photomultipliers were encoded and recorded using a Tracor 1705 multichannel analyser.

The choice of the photomultiplier for the reference channel is critical; the requirement being that it must remain stable in all respects over the entire duration of a cycle of tests - in practice about twelve hours. A specially selected and aged photomultiplier was used for this purpose. A complete system check was carried out to verify the stability and consistency of the entire apparatus and method. Over a period of three days of continuous measurement the same pair of tubes was repeatedly measured over the entire temperature and wavelength band. The reproducibility was found to be entirely satisfactory provided that the high voltage was applied for at least twelve hours prior to measurement

Because of the design of the experiment, the results are independent of fluctuations in the light source intensity provided that output pulse height distributions are simultaneously measured from the pair of photomultipliers. This requires two multichannel analysers, which proved to be inconvenient. In practice it was found that with the light source in continuous operation, one analyser was sufficient, provided that the acquisition time for results was of the order of a minute. Dark counts were measured for both photomultipliers by interposing a shutter following the acquisition of the pair of signal results. The dark counts were subtracted from the initial measurements to give the true signal rate.

Using a combination of neutral density filters and adjustment of the light intensity, the single electron count rate was set in the region of $1 - 2 \times 10^4$ per second. This is a satisfactory compromise between attaining acceptable counting statistics without incurring excessive analyser dead-time.

Measurements were repeated at each temperature until successive sets of signal - background results agreed. Usually no more than two sets were required at each temperature.

results

Ten photomultipliers selected from the types listed in **table 1** were measured. The spectral sensitivity⁵ was measured for each photomultiplier to obtain λ_0 , the long wavelength cut-off (the wavelength at which the quantum efficiency is $<0.01\%$).

table 1 these particular types were selected because of the high gain capability and well-resolved single electron resolution (SER). The former is a requirement for photon counting whilst a good SER is a desirable although not essential attribute for the method. The effect on the gain upon cooling by 40°C is illustrated in **figure 2**.

photomultiplier type	photo-cathode	dynode material	number studied
9813	KSbCs	BeO	3
9816	S20	BeO	2
9820	KSbCs	SbCs	2
9954	RbCsSb	BeO	2

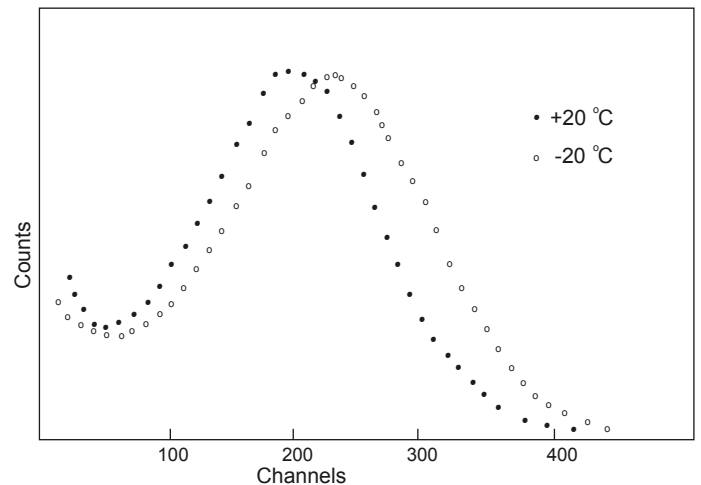

figure 2 the single electron response of a photomultiplier measured at two temperatures. The shift in the peak position is used to calculate α_m and the change in area under each curve relates to the change in quantum efficiency. **Note** the peak shifts to the right with cooling.

The shift in the peak position of the SER can easily be estimated to half a channel, corresponding to 0.5%. The change in quantum efficiency and hence $\alpha(\lambda)$ is calculated from the ratio of the integral counts at the two temperatures. For this purpose the integral was taken from 0.25 to 4 photoelectrons equivalent, where the peak by definition is taken as one photoelectron equivalent. These limits are not critical in the calculation of $\alpha(\lambda)$ as can be readily seen from inspection of the SER. The quality of the SERs for the photomultipliers selected varied with regard to their individual peak-to-valley ratios. However, without exception, it was noted that the shape of the SER was invariant to temperature. The results for six photomultipliers are shown in **figure 3**, which illustrates that all samples tested have a negative gain coefficient, although of different magnitude.

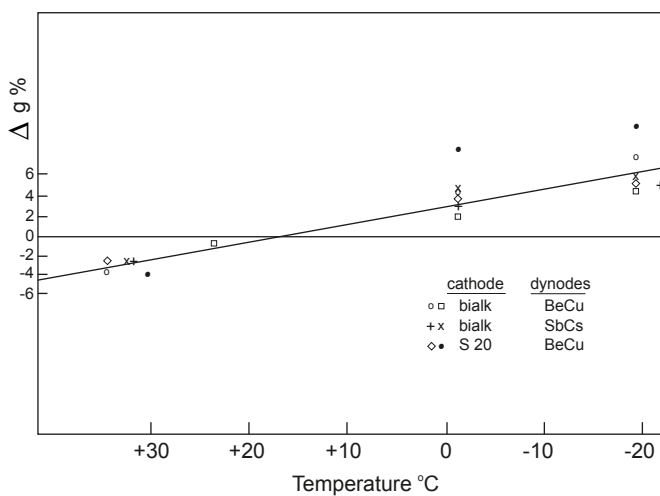

figure 3 multiplier gain changes derived from pairs of curves similar to those seen in **figure 2**. Δg is the change in gain relative to 10°C . The straight line represents $\alpha_m = -0.2\% / ^\circ\text{C}$. Note that the SbCs dynodes appear to have the same temperature dependence as do the BeCu dynodes. The temperature dependence of the photocathode response is illustrated in **figure 4**.

The shapes of the $\alpha(\lambda)$ vs λ curves appear to have a common profile (Serial Number 4406 is the exception). $\alpha(\lambda)$ is negative at 400 nm, approximately zero for 450 - 550 nm, and then negative until λ_0 is approached. There is a correlation between the cut-off of the spectral response, λ_0 , and the wavelength at which $\alpha(\lambda)$ begins to change very rapidly with temperature (for the S20s in **figure 4** this wavelength is approximately 850 nm).

Measurements were taken at ten degree intervals, and it was found that over the range -20 to +40 °C both coefficients were temperature independent.

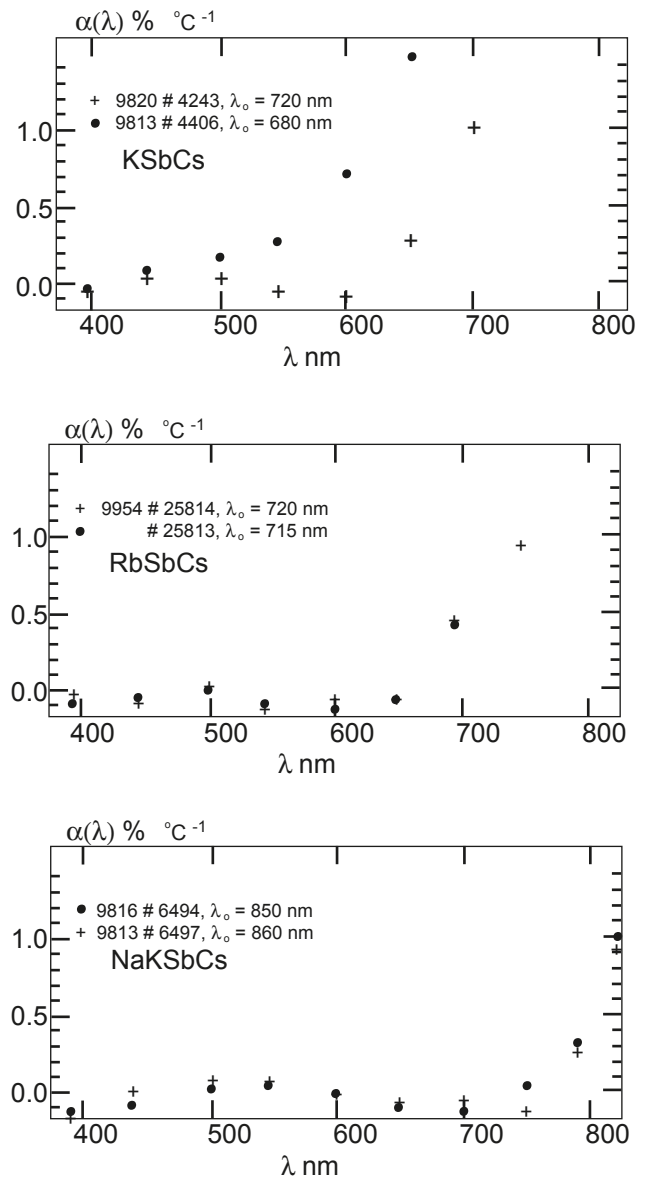

figure 4 photocathode sensitivity coefficients, $\alpha(\lambda)$ for the three photocathode types. The cut-off wavelengths are given for each photocathode.

discussion

Miyazawa⁶ has suggested that the long wavelength sensitivity is related to a change in photoelectric work function ϕ with temperature. For an S11 photocathode he quotes the following results: $d\phi/dT \simeq -4 \times 10^{-4} \text{ eV}/^\circ\text{C}$. It is interesting to note that this relationship is approximately true for the range of photocathodes studied in the present work. With regard to temperature dependence of the secondary emission coefficient, Dekker⁷ provides a formula that ascribes the effect to a decrease in energy loss due to lattice scattering. For MgO, a dynode material similar to BeO, Dekker calculates α_m as -0.02% per degree C. The photomultipliers used in this investigation were either 12 or 14 stage devices which corresponds to -0.016% $^\circ\text{C}$ per stage, which is of the same order as for MgO.

It is difficult to put a figure on the accuracy of the measurements because of the unknown systematic errors. However, using repeated measurements as a guide, the present results are reliable to 5%. There are practical implications of this work, some also noted by Young², which are worth expanding upon.

1 Cooling the photomultiplier enhances the quantum efficiency to wavelengths approaching λ_0 . In the immediate region of λ_0 cooling reduces the quantum efficiency. If a photomultiplier is used at wavelengths close to the cut-off then clearly the response will be sensitive to small changes in temperature to the extent of 1% per degree C. In cooling a photocathode one is usually trading dark counts for a quantum efficiency, but below a certain temperature the signal to background ratio may well decrease.

2 The extent to which a detector is sensitive to temperature depends on the application. Young² has already pointed out the advantages of photon counting in astronomical applications - the results are insensitive to changes in multiplier gain. In applications such as scintillation counting and spectrometry, the output is sensitive to both $\alpha(\lambda)$ and α_m .

references

- [1] R B Murray and J J Manning,
"Response of End-Window Photomultiplier Tubes
as a Function of Temperature".
IRE Trans NS-7, pp 80-86, 1960.
- [2] A T Young,
"Temperature Effects in Photomultipliers and
Astronomical Photometry".
Applied Optics, Vol. 2, No. 1, pp 51-60, January 1963
- [3] M R Cole and D V Ryer,
"Cooling of PMT Tubes for Best Spectral Response",
Electro-Optical System Design, Vol. 4, No. 6, pp 16-19,
June 1972.
- [4] F E Kinard,
"Temperature Dependence of Photomultiplier Gain",
Nucleonics, pp 90-97. April 1957.
- [5] Electron Tubes Photomultiplier Brochure, p5, 1986.
- [6] H Miyazawa,
"Photoelectric Emission and Energy Structure of Cs3Sb",
J. Phys Soc. Japan, Vol. 8, No. 2, March 1953.
- [7] A J Dekker,
Solid State Physics, London, Macmillan, 1958.
- [8] H Martin,
"Cooling Photomultiplier with III-V Photocathodes",
Electro-Optical Systems Design, pp 16-20,
November 1976.

Copyright 1987 IEEE.
Reprinted with permission, from
IEEE TRANSACTIONS ON NUCLEAR
SCIENCE, Vol. NS-34, No. 1, pp 434-437,
February 1987.

talk to us about your application or choose a product from our literature:

photomultipliers, voltage dividers, signal processing modules, housings and power supplies



ET Enterprises Limited
45 Riverside Way
Uxbridge UB8 2YF
United Kingdom
tel: +44 (0) 1895 200880
fax: +44 (0) 1895 270873
e-mail: sales@et-enterprises.com
web site: www.et-enterprises.com

ADIT Electron Tubes
300 Crane Street
Sweetwater TX 79556 USA
tel: (325) 235 1418
toll free: (800) 521 8382
fax: (325) 235 2872
e-mail: sales@electrontubes.com
web site: www.electrontubes.com

choose accessories for this pmt on our website

an ISO 9001 registered company

The company reserves the right to modify these designs and specifications without notice. Developmental devices are intended for evaluation and no obligation is assumed for future manufacture. While every effort is made to ensure accuracy of published information the company cannot be held responsible for errors or consequences arising therefrom.

ET Enterprises 
electron tubes

© ET Enterprises Ltd, 2011
DS_R/P081 Issue 3 (18/01/11)